

Ruler



	BY	Date
Modeled		
Drawn		

Drawing area

Note

Name and info of company

Name of products

Scale

Weight

Sheet



Ruler

- 1) Name of products-title of your products
- 2) Scale between blueprints and real product
- 3) Weight of future product
- 4) Sheet that now edit
- 5) Name and info of company that create this products
- 6) Note that shown in content in drawing area
- 7) Drawing area-your working area where you draw your future products



Ruler

	BY	Date
Modeled	R Benson	07/26/2010
Drawn	R Benson	07/31/2010

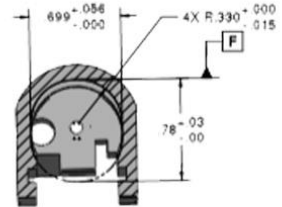
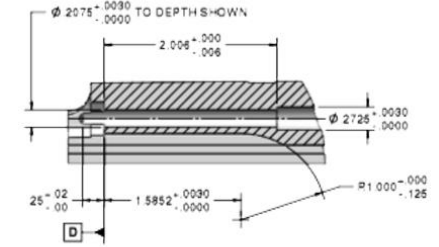
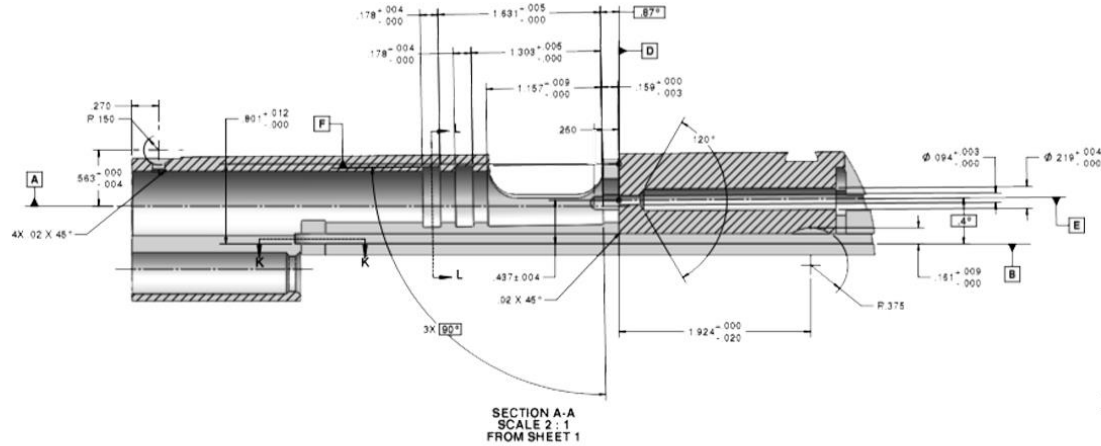

SECTION L-L
SCALE 2:1
BREECH LOCK PROFILE
3 PLACES ALONG DATUM F

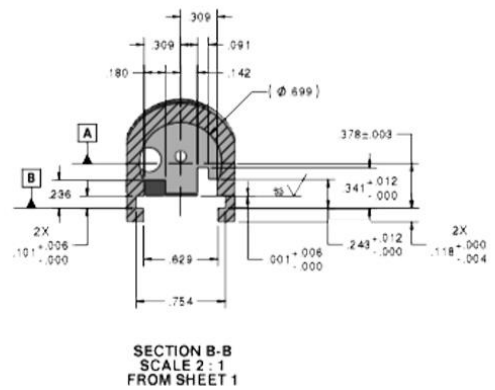

UNLESS OTHERWISE SPECIFIED:
DIMENSIONS ARE IN INCHES.
TOLERANCES: ANGULAR ±.5°
2 PL ±.01, 3 PL ±.005, 4 PL ±.0005,
SYMM & CONC: 1/2 FEATURE
TOL., FAB FINISH: 125
MICROINCHES. BRK/FIL SHARP
COR .005 MAX. DIM & TOL IAW
ASME Y14.5-1994.

Benson Consulting, LLP

Gastonia, NC 28054 • rhbenison@earthlink.net • 1-704-860-1202

SLIDE

1st MADE FOR: M1911-A1 REDUX

SCALE: 3:2 WEIGHT: 0.83 LB SHEET 1 of 2



Ruler