

ARMY RESEARCH LABORATORY



IGES 4.0 to BRLCAD Translator for CSG Models

John R. Anderson
Earl P. Weaver
Susanne L. Muuss

ARL-TR-315

December 1993

NOTICES

Destroy this report when it is no longer needed. DO NOT return it to the originator.

Additional copies of this report may be obtained from the National Technical Information Service, U.S. Department of Commerce, 5285 Port Royal Road, Springfield, VA 22161.

The findings of this report are not to be construed as an official Department of the Army position, unless so designated by other authorized documents.

The use of trade names or manufacturers' names in this report does not constitute indorsement of any commercial product.

REPORT DOCUMENTATION PAGE			Form Approved OMB No. 0704-0188	
Public reporting burden for this collection of information is estimated to average 1 hour per response, including the time for reviewing instructions, searching existing data sources, gathering and maintaining the data needed, and completing and reviewing the collection of information. Send comments regarding this burden estimate or any other aspect of this collection of information, including suggestions for reducing this burden, to Washington Headquarters Services, Directorate for Information Operations and Reports, 1215 Jefferson Davis Highway, Suite 1204, Arlington, VA 22202-4302 and to the Office of Management and Budget, Paperwork Reduction Project (0704-0188), Washington, DC 20503.				
1. AGENCY USE ONLY (Leave blank)	2. REPORT DATE December 1993	3. REPORT TYPE AND DATES COVERED Final, January 1991-April 1992		
4. TITLE AND SUBTITLE IGES 4.0 to BRLCAD Translator for CSG Models			5. FUNDING NUMBERS PR: 1L162618AH80	
6. AUTHOR(S) John R. Anderson, Earl P. Weaver, and Susanne L. Muuss				
7. PERFORMING ORGANIZATION NAME(S) AND ADDRESS(ES) U.S. Army Research Laboratory ATTN: AMSRL-SL-BV Aberdeen Proving Ground, MD 21005-5066			8. PERFORMING ORGANIZATION REPORT NUMBER	
9. SPONSORING / MONITORING AGENCY NAME(S) AND ADDRESS(ES) U.S. Army Research Laboratory ATTN: AMSRL-OP-CI-B (Tech Lib) Aberdeen Proving Ground, MD 21005-5066			10. SPONSORING / MONITORING AGENCY REPORT NUMBER ARL-TR-315	
11. SUPPLEMENTARY NOTES				
12a. DISTRIBUTION / AVAILABILITY STATEMENT Approved for public release; distribution is unlimited.			12b. DISTRIBUTION CODE	
13. ABSTRACT (Maximum 200 words) This report discusses the subject of importing IGES 4.0 format (Initial Graphics Exchange Specification Version 4.0) computer-aided design (CAD) constructive solid geometry (CSG) models into the former Ballistic Research Laboratory's Computer-Aided Design (BRLCAD) package, and describes the results of a software development project to implement an IGES-to-BRLCAD translator that conforms to the ASME Y14.26M-1989 Standard. The report also presents a brief description of the IGES philosophy and specification, the relationship between IGES and the American National Standards Institute (ANSI) <i>standard</i> on the exchange of product definition data, limitations of the current specifications/standards and BRLCAD, suggested solutions for overcoming those limitations, and recommendations for future work.				
14. SUBJECT TERMS computer aided design; information exchange; IGES; BRLCAD, CSG; geometric modeling			15. NUMBER OF PAGES 24	
			16. PRICE CODE	
17. SECURITY CLASSIFICATION OF REPORT UNCLASSIFIED	18. SECURITY CLASSIFICATION OF THIS PAGE UNCLASSIFIED	19. SECURITY CLASSIFICATION OF ABSTRACT UNCLASSIFIED	20. LIMITATION OF ABSTRACT SAR	

NAME OF CONTRIBUTOR

ADDRESS OF CONTRIBUTOR

CITY AND STATE

ZIP CODE

INTENTIONALLY LEFT BLANK.

PREFACE

The U.S. Army Ballistic Research Laboratory was deactivated on 30 September 1992 and subsequently became a part of the U.S. Army Research Laboratory (ARL) on 1 October 1992.

CONFIDENTIAL - This document contains information that is exempt from public release under the Freedom of Information Act, 5 U.S.C. 552(b)(7)(C). This information is being disseminated to you for your use only and is not to be distributed outside your organization.

INTENTIONALLY LEFT BLANK.

TABLE OF CONTENTS

	<u>Page</u>
PREFACE	iii
LIST OF FIGURES	vii
1. INTRODUCTION	1
2. SOLID MODELS	1
3. IGES	3
4. IGES-TO-BRLCAD APPROACH	7
5. CURRENT STATUS	9
6. FUTURE PLANS	13
7. RECOMMENDATIONS	16
REFERENCES	19
DISTRIBUTION LIST	21

TABLE OF CONTENTS

1	INTRODUCTION	1
2	STATEMENT OF PURPOSE	2
3	SCOPE OF THE STUDY	3
4	DEFINITION OF TERMS	4
5	REVIEW OF RELATED LITERATURE	5
6	RESEARCH METHODOLOGY	6
7	DATA COLLECTION	7
8	ANALYSIS AND DISCUSSION	8
9	CONCLUSION	9
10	REFERENCES	10
11	APPENDICES	11
12	INDEX	12

INTENTIONALLY LEFT BLANK.

LIST OF FIGURES

<u>Figure</u>	<u>Page</u>
1. IGES Drawing Produced by an ANVIL 5000 System	4
2. ASCII 80-Character Record Form of IGES File	5
3. Boolean Tree Example	7
4. Subtree Transformation	8
5. BRLCAD-Compatible Tree	9
6. Model Received From a Calma CAD System	10
7. Part Model Used for AUTOFACT V Demonstration	10
8. Different View of Figure 7 Model	11
9. Still Another Calma Model	11
10. Original BRLCAD Model	12
11. Model After Translation To/From IGES	12
12. BRLCAD Model: Building Resting on a Mirror	12
13. Figure 12 Model After Translation To/From IGES	12

1

2

3

4

5

6

7

8

INTENTIONALLY LEFT BLANK.

9

10

11

12

13

14

15

1. INTRODUCTION

During the late 1970s, engineers and information scientists saw the need to communicate designs, in the form of engineering drawings, among the variety of computer-aided *drafting* (CAD) systems coming into widespread use within the engineering community. Personnel from Boeing and General Electric collaborated on a scheme to make it possible for different CAD systems to exchange data without resorting to special programs to translate from one internal database to all the other possible formats.¹ The scheme was conceptually simple: define a file format that all systems could understand (i.e., read and write). Then when two different CAD systems needed to exchange data, the sender would produce the neutral data file for the receiver to read. Out of this early work evolved the Initial Graphics Exchange Specification (IGES), which was developed by an all-volunteer organization including representatives from industry, government, and academia.² The first *specification* was completed in 1980 and became an American National Standards Institute (ANSI) *standard* in 1981.³ The original specification dealt mainly with the representation of two-dimensional engineering drawings, but did include some capability to exchange three-dimensional curves and surfaces. As CAD systems evolved from purely drafting applications to computer-aided drafting and design (CADD) functions, then to today's computer-aided *design* (CAD) workstations with solid modeling capabilities, the IGES community recognized the need for a mechanism to exchange solid models as well as flat drawings. The IGES 4.0 specification, completed in June of 1988, includes capabilities to represent constructive solid geometry models.⁴ This version of IGES became an ANSI standard (ASME Y14.26M-1989) in 1989 and is entitled "Digital Representation for Communication of Product Definition Data."⁵ ASME Y14.26M-1989 is the current standard and is the basis for the work presented in this report. But the latest version of IGES—Version 5.1—was released in September of 1991 and will soon begin the process toward becoming an ANSI standard. The major enhancement in IGES 5.1 is additional capability in the solid modeling area—namely, support for boundary representation models.⁶ When this IGES version becomes a standard, the capabilities will exist for virtually complete exchange of solid models among unlike CAD systems.

2. SOLID MODELS

Generally, there are three accepted types of solid modeling techniques

- Constructive Solid Geometry (CSG)
- Boundary Representation (BREP), and
- Hybrids.

The CSG system uses a variety of (generally simple) primitive solid shapes, such as cones, cylinders, spheres, ellipsoids, boxes, and so forth, as the basis for the construction of more complex objects by employing combining operators such as union, intersection, and subtraction. Often the combining operators are called *booleans*. Sometimes the familiar combining operations are hidden from the user, but they are

still there nevertheless. For example, in a feature-based CSG system, the user can “drill” a hole through an object by specifying a *hole* command, rather than by explicitly defining the “hole” as a subtraction of the appropriate cylinder from the object. However, the subtraction operator and the operands are stored by the CSG system (as a form of boolean *tree*) to define the new object.

The BREP systems create solid objects by defining a surface (or a collection of surfaces) that completely encloses the volume of the object. The shape of the surface(s) defines the shape of the object. These surface definitions often include a variety of forms such as B-splines, Bezier patches, Coons patches, simple planes, or merely faceted (tessellated) surfaces.

Hybrid systems are a combination of both CSG and BREP. The user, typically, can choose from a palette of simple shapes and then use combining operations to produce a model; or the user may select from a variety of surfaces and trim, cut, or otherwise manipulate them to define the model. However, nearly all hybrid systems evaluate their CSG constructs to produce a final BREP form of the model. The current release of the Army Research Laboratory’s (ARL) Computer-Aided Design package (BRLCAD 4.0) is a hybrid system, although its CSG capabilities are most visible and available to the user in the interactive editor *mged*, and BRLCAD does not generally produce the final model as a BREP. The spline-surfaced solid, the *ARS* solid, the *polysolid*, and the new *NMG* solid are all examples of BREP-type objects.

As designers became more dependent on CAD systems, there was a logical progression into solid modeling because of its useful potential. Remember, human beings invented engineering drawings to capture and communicate design intent among *humans*. But now humans are coming to realize that machines can recognize design intent more easily in forms other than three-view engineering drawings. Today’s emphasis is on machine-to-machine communication, often linking the design of a part (on one machine) to ultimately the computer-driven machine tool (on another machine). Thus, the solid model is emerging as *the* specification of the part (the product definition). Accordingly, many CAD vendors include solid modeling capabilities in their systems and some are including additional applications capabilities such as finite element analysis based on the solid model. (The term *computer-aided engineering* (CAE) is evolving as the descriptor used to distinguish the workstation with these new capabilities from the traditional CAD faculty.) As the engineers in the 1970s realized that some method was needed for exchanging CAD-generated engineering drawings between CAD systems, now they realize that the same need exists for CAD-generated solid models.

3. IGES

One might ask that if translators between CAD system **A** and **B** were required, then why not produce those direct translators instead of using the neutral file format scheme of IGES? For a small number of CAD systems that solution may be reasonable, but consider how many translators would be needed for exchange between a large number of systems. For each and every pair of CAD systems two translators are required, one for each direction (i.e., one to produce the data file and another to read the data file). The number of translators required for full exchange capability among a group of n CAD systems is

$$n (n - 1).$$

The number of translators required for a data exchange via IGES is simply

$$2n,$$

because every CAD system requires just two translators (one for incoming and one for outgoing). Note that the number of IGES translators required for the IGES scheme increases only linearly with the number of CAD systems, while the number required for direct translation increases as the *square* of the number of CAD systems.

Nearly every CAD system on the market today supports exchange of two-dimensional drawings via IGES. An example of a drawing received at ARL in IGES format is shown in figure 1⁷. Although the IGES form of that drawing has no direct application to generating a solid model of the helicopter in the BRLCAD system, it must be noted that the IGES file does contain data suitable for capture by a preprocessor that could simplify the making of the solid model. Work is in progress with just that objective; however, that exploitation of IGES is beyond the scope of this report.

The IGES specification defines a neutral file format for the exchange of product definition data. This neutral file may be in one of three formats: ASCII, compressed ASCII, or binary. The ASCII form is the most commonly used and is the only form considered in this report. This format is based on fixed-length 80-character records. The ASCII file format consists of five sections, a start section, a global section, a directory section, a parameter section, and a terminate section. Figure 2 shows an example of an ASCII format IGES file.

The start section is merely a place for any human-readable comments that the sender wishes to include. The global section contains information for use by the post-processor (receiving translator) such as the units used in the IGES file, a scale factor, the date the file was generated, the sender's name, and so forth. The actual data in the IGES file are recorded as a number of *entities*. Each entity has a specific

purpose and a specific format within the file. Each entity must have its own entry in the directory section. Directory section entries consist of two 80-character records that contain information about that particular entity such as what type of entity it is, whether this entity requires a transformation matrix applied to it (and where the directory entry for the matrix can be found), the form number (if required), the color of the object, and where the parameters that define this entity are located. The pointers in the directory section that indicate where other data are to be found are simply sequence numbers—literally, line numbers—usually in the parameter section. The parameter section contains the detailed data for each entity in a free-form style with each field separated by an end-of-field delimiter and each record terminated with an end-of-record delimiter. Both these delimiters are defined in the global section. The parameter section is followed by the terminate section which consists of a single 80-character record containing the number of records used for each section of the file.

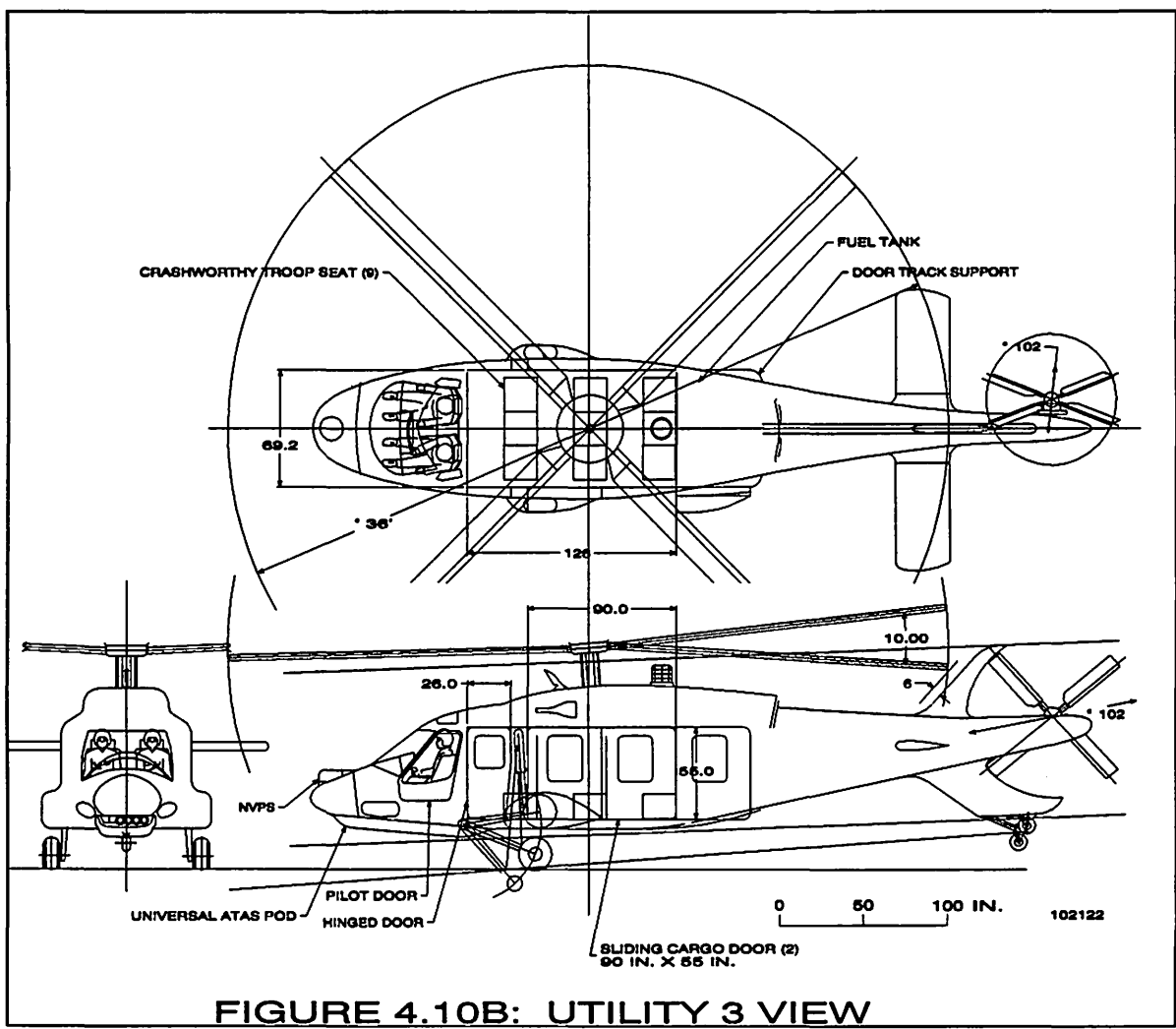

FIGURE 4.10B: UTILITY 3 VIEW

Figure 1. IGES Drawing Produced by an ANVIL 4000 System

IGES supports the following entities for a CSG solid model

1. Block
2. Right Angular Wedge
3. Right Circular Cylinder
4. Right Circular Cone Frustum
5. Sphere
6. Torus
7. Ellipsoid
8. Solid of Revolution

IGES file generated from an AutoSolid assembly by the								S	1
IGES translator from Autodesk Inc., translator version IGES3.0								S	2
								S	3
1H,,1H;4Htest,8Htest.igs,13HAutoSolid 3.1,7HIGES3.0,32,8,24,12,52,								G	1
4Htest,1.0,1,4HINCH,32767,32.766998,13H910326.082948,9.9999999E-09,2.0,								G	2
12HWiley Coyote,10HACME, Inc.,4,0;								G	3
106	1	0	1	1	0	0	000000001D	1	
106	0	0	34	11			OD	2	
106	35	0	1	1	0	0	000000001D	3	
106	0	0	34	11			OD	4	
106	69	0	1	1	0	0	000000001D	5	
106	0	0	34	11			OD	6	
106	103	0	1	1	0	0	000000001D	7	
106	0	0	34	11			OD	8	
106	137	0	1	1	0	0	000000001D	9	
106	0	0	34	11			OD	10	
106	171	0	1	1	0	0	000000001D	11	
106	0	0	34	11			OD	12	
.									
.									
.									
106	3557	0	1	1	0	0	000000001D	371	
106	0	0	17	11			OD	372	
106,1,100,0.0,4.6999984,4.8564682,4.6507363,4.7730103,4.5999112,								1P	1
4.6905069,4.5475774,4.6090484,4.4937944,4.5287275,4.4386225,								1P	2
4.4496326,4.3821225,4.3718529,4.3243594,4.2954755,4.2653952,								1P	3
4.2205844,4.205297,4.1472645,4.1441326,4.0755973,4.0819688,								1P	4
4.0056624,4.0188761,3.9375384,3.9549243,3.8713012,3.8901856,								1P	5
3.8070247,3.7586362,3.6846399,3.6248152,3.57093,3.4893196,								1P	6
3.4664021,3.3527555,3.3715241,3.2157328,3.2867198,3.0788629,								1P	7
3.2123673,2.9427569,3.1487987,2.8080232,3.0962982,2.6752639,								1P	8
3.0551007,2.5450716,3.0253897,2.4180274,3.0072975,2.2946992,								1P	9
3.0009055,2.1756375,3.006242,2.0613742,3.0232835,1.9524195,								1P	10
3.0519536,1.8492601,3.092124,1.7523569,3.143616,1.6621425,								1P	11
3.2061987,1.5790197,3.2795932,1.5033599,3.363472,1.435501,								1P	12
3.4574594,1.3757461,3.5611365,1.3243622,3.6740403,1.2815784,								1P	13
3.7956665,1.2475864,3.9254713,1.2225373,4.0628753,1.2065434,								1P	14
.									
.									
.									
-1.7722948,-3.7763236,-1.7160469,-4.0600858,-1.6852584,								371P	3571
-4.3611131,-1.6806873,-4.6719942,-1.7024462,-4.9850731,								371P	3572
-1.7499994,-5.2926416;								371P	3573
S	3G	3D	372P	3573			T	1	

Figure 2. ASCII 80-Character Record Form of IGES File

9. Solid of Linear Extrusion
10. Solid Instance
11. Boolean Tree
12. Solid Assembly

The first seven of these entity types are simple primitive shapes, and the directory section entry for each would contain a pointer to a parameter section entry that contains data such as vertices, radii, length vectors, and so forth. The parameter section entry for the solid of revolution would contain a pointer to another directory entry for some type of curve definition entity as well as a point, axis, and a rotation angle. The curve is rotated about the axis through the rotation angle to generate (define) the solid. The solid of linear extrusion specifies a closed curve (representing the cross section of the extrusion) and a vector to define the direction and distance the cross section is to be extruded.

Both the solid of revolution and the solid of linear extrusion may make use of any of the IGES curve entities. These curves may be specified using any of the following entity types:

1. Circular Arc
2. Conic Arc
3. Line
4. Copious Data
5. Parametric Spline
6. Rational B-Spline
7. Composite Curve

The first three of these are obvious curve types. The copious data curve is merely a series of data points to be connected by straight lines. The splines offer two types of smooth curves, and the composite curve is a single curve with a series of segments made up of any mix of the above curve types (including more composite curves).

The solid instance entity allows a copy of another solid to be used without redefining it and includes the capability to apply a different transformation matrix to the copy. The boolean tree entity describes the operations and operands to build an object which may be the entire model under consideration or just a small part. The operators allowed in the boolean tree are intersection, union, and subtraction. The operands may be any CSG solid, solid instances, or other boolean trees. The solid assembly entity defines a collection of items that share a fixed geometric relationship. Any solid objects may be grouped by this entity.

4. IGES-TO-BRLCAD APPROACH

Most of the CSG entities in IGES can be directly converted to a corresponding object in BRLCAD—however, there are a few exceptions. The block and the right angular wedges convert directly to the BRLCAD *genarb8* solid. The right circular cylinder and right circular cone frustum entities convert directly to the *gentgc* solid; the sphere and ellipsoid entities convert to the *genell* solid; and, of course, the torus entity converts directly to the BRLCAD *tor* solid. The solid instance entity is implemented by simply creating another copy of the instanced solid in the BRLCAD model.

The solid of linear extrusion—one of the exceptions noted above—is not currently a supported primitive in BRLCAD, so we approximate it by using a combination of other BRLCAD primitives. In cases where the curve to be extruded is simply a single circular or conic arc, then a BRLCAD *gentgc* solid is produced. If the curve to be extruded is anything else, we approximate the curve by a series of straight line segments and a BRLCAD *polysolid* is built. The sides are all polygons of four vertices and the top and bottom surfaces are simply additional polygons to close the ends.

The solid of revolution is also implemented by approximating the defining curve as a series of straight line segments. When the approximating curve is revolved, each straight line segment generates a BRLCAD *gentgc* solid. This “stack” of solids is then combined to form the final approximation to the IGES entity. Exactly how these solids are combined depends on the *form number* of the IGES solid. The form number is another piece of data that is included in the directory section entry for each entity. For a solid of revolution, the form number indicates whether the curve to be revolved is closed upon itself or is closed upon the axis of revolution. If the curve is closed upon the axis of revolution, then the final object is merely the union of all the approximating solids. If the curve is closed upon itself, then the final object must have a hollow section through the center, and the approximation must be built with the appropriate combination of unions and subtractions of the “stack” of solids.

The solid assembly entity is directly analogous to the BRLCAD *group* and is converted directly to that form. The boolean tree entity, however, presented some difficulties. IGES

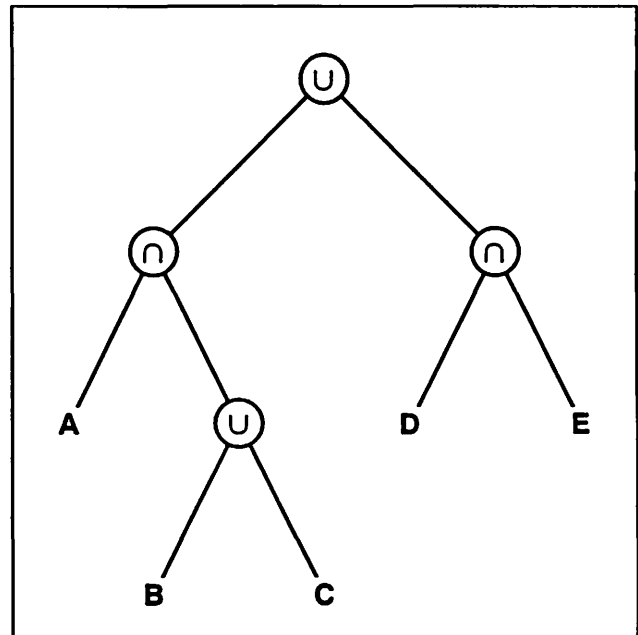

Figure 3. Boolean Tree Example

defines the boolean tree in a postorder notation that allows for easy construction of a binary tree in memory through the use of a stack algorithm. An example of a boolean tree is shown in figure 3. The postorder notation that an IGES translator would produce for this tree is

A B C U D E N U.

The equivalent infix notation for this tree is

(A ∩ (B ∪ C)) ∪ (D ∩ E).

Note that the parentheses are required for correct evaluation of this tree.

Since BRLCAD does not support postorder notation nor permit parenthetical expressions in region definitions, an IGES boolean tree cannot be directly converted to a BRLCAD region, in general. Because of its ancestry, BRLCAD has inherited the property that there are implied parentheses at the union operators, i.e., all the operations between the union operators are performed first, then the unions are evaluated. These facts lead to some restrictions on the form of the boolean trees that may be directly converted to BRLCAD regions. These restrictions may be summed up by saying that no union operator may appear at a node in the tree below any nonunion operator. In general, any boolean tree may be rewritten to satisfy that requirement by applying a series of

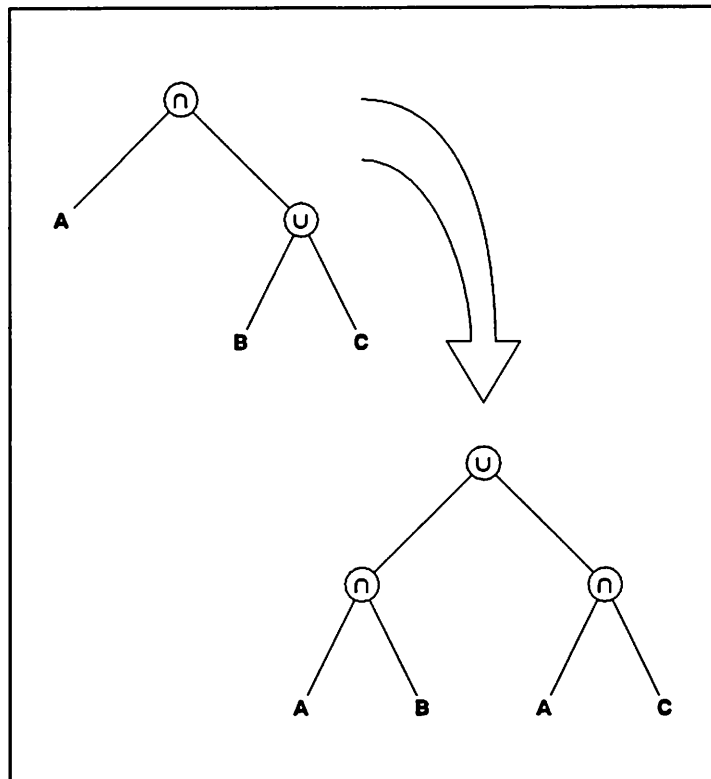

Figure 4. Subtree Transformation

transformations to its subtrees. An example of just such a transformation is shown in figure 4. Here, a subtree of the previous example illustrates a situation where a union operator appears below an intersection operator. This subtree is easily rewritten (as shown in the figure) to move the union operation up the tree. When this subtree is placed back in the original tree, the result is a tree that conforms to the BRLCAD syntax—while still producing the same resultant object. Figure 5 illustrates the final tree structure, which can now be expressed in BRLCAD syntax as

A + B ∪ A + C ∪ D + E,

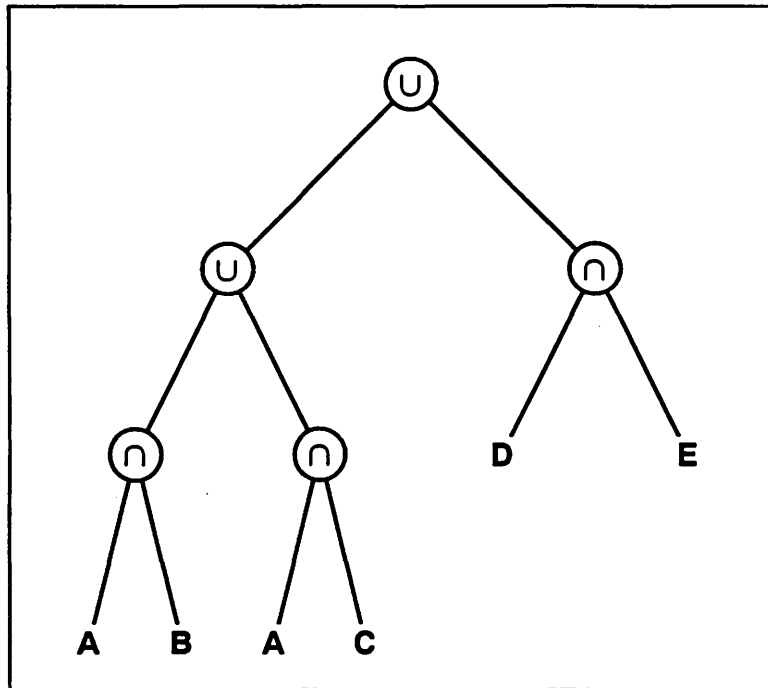

Figure 5. BRLCAD-Compatible Tree

where \cap is the intersection operator (\cap), and \cup is the union operator (\cup). This region is then constructed in the BRLCAD model.

A series of transformations was developed to convert from IGES postorder notation to BRLCAD syntax by examining all possible subtree situations where a union operator appears below a nonunion operator and constructing an equivalent tree with the union operator at the top. The only remaining difficulty is the fact that IGES allows boolean trees to reference other boolean trees. In BRLCAD, a group may reference another group, but a region referencing another region is generally not supported. Since BRLCAD groups are only unions of a collection of objects, it appears that after having solved the boolean tree problem, neither the BRLCAD *region* nor the BRLCAD *group* will satisfy our requirements. However, the regions and groups in BRLCAD are really just varieties of the same type of object—called a *combination* in BRLCAD—with a flag in the structure indicating that a particular object is a region. BRLCAD actually supports combinations that reference other combinations as long as the combination isn't flagged as a region. So the resulting boolean trees from IGES may be converted to BRLCAD *combinations*.

5. CURRENT STATUS

An IGES-to-BRLCAD translator (post-processor) has been developed based on the ANSI standard ASME Y14.26M-1989, which is essentially IGES 4.0. Therefore, this translator accommodates (with

approximations in some cases) all the ANSI (i.e., IGES) CSG entities. The translator does not support the IGES BREP entities from IGES Version 5.1 The current translator reads the IGES file, checks for correct syntax, then proceeds to construct the BRLCAD model. The translator makes extensive use of the BRLCAD *libwdb* package, thus avoiding concerns about the details of the BRLCAD database format as well as future concerns about changes to that format. The following routines from *libwdb* are used:

1. `mk_id`—creates an ident record for the entire database
2. `mk_rcc`—creates a right-circular cylinder
3. `mk_trc`—creates a truncated right-circular cone
4. `mk_tgc`—creates a truncated general cone
5. `mk_arb8`—creates a polyhedron of eight vertices
6. `mk_sph`—creates a sphere
7. `mk_ell`—creates a general ellipsoid
8. `mk_tor`—creates a torus
9. `mk_addmember`—adds a name to a list of members for future inclusion in a group
10. `mk_lcomb`—creates a combination, region, or group.

When transformation matrices and translations are present in an IGES file, they follow the same convention as BRLCAD does and can be used as arguments in the `mk_addmember` calls for building combinations. Any transformations applied to top level objects are applied by creating a new top level group named “all” that contains all unreferenced objects with their transformations applied.

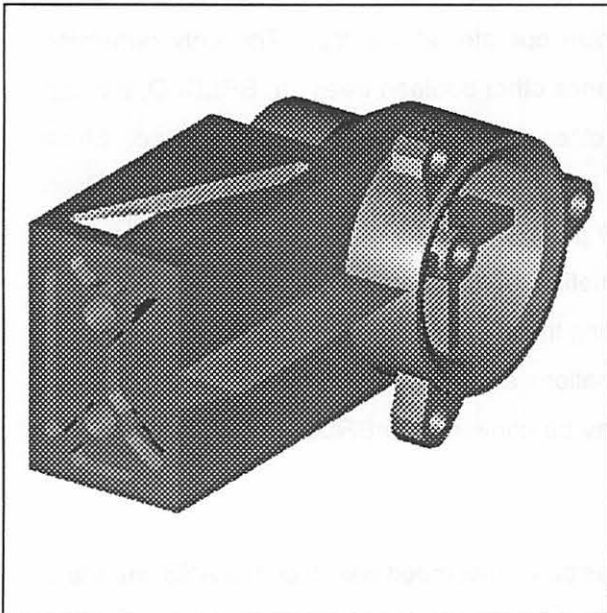

Figure 6. Model received from a Calma CAD system

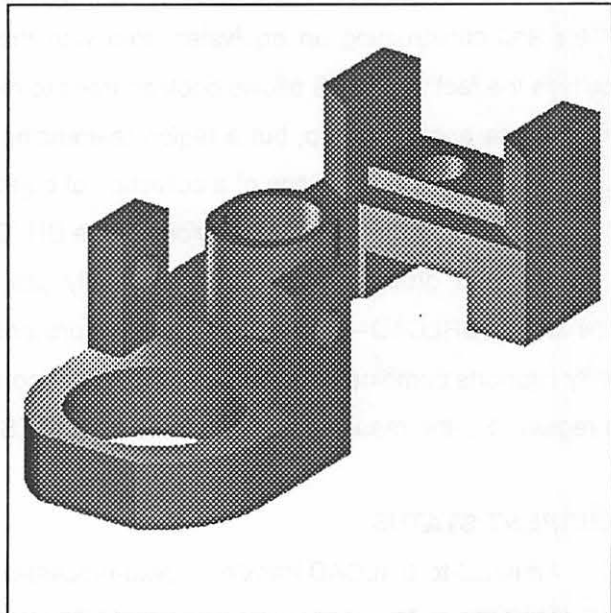

Figure 7. Part Model used for AUTOFACT V demonstration

The IGES-to-BRLCAD post-processor described above has been implemented and has been successfully exercised on a number of actual IGES CSG files. Some of these files were obtained from CAD systems that support IGES and some were hand developed for the purpose of testing this software. Figures 6 through 9 illustrate solid models that were originally generated on a Calma CAD system and translated to BRLCAD via IGES.⁸ The models were converted to BRLCAD using the IGES-to-BRLCAD translator and then rendered by BRLCAD's ray-tracer *rt*.

These models contained some of the IGES entities that are not supported by BRLCAD. However, the resulting models are certainly acceptable for most applications. The necked-down cylinder portion of the part in figure 6 is a solid of revolution (and approximated by a combination of BRLCAD *gentgc* primitives as described above). The three "ears" on the same part are solids of linear extrusion (and are BRLCAD *polysolid* approximations). Figures 7 and 8 show two views of a model that was used as the AUTOFACT V demonstration part. AUTOFACT is a national convention focusing on manufacturing technology and the transfer of part designs from system to system. The model in Figure 9 contains three solids of linear extrusions and five solids of revolution. In spite of our translator's approximations, we think the reader will agree that the resulting BRLCAD model looks like a reasonable object (whatever it is).

Figures 10 through 13 illustrate original BRLCAD models that have been converted to the IGES format and then translated back to BRLCAD via the current IGES translator. The translation to IGES was performed by a rudimentary translator with some manual file editing. For practical purposes, the tin

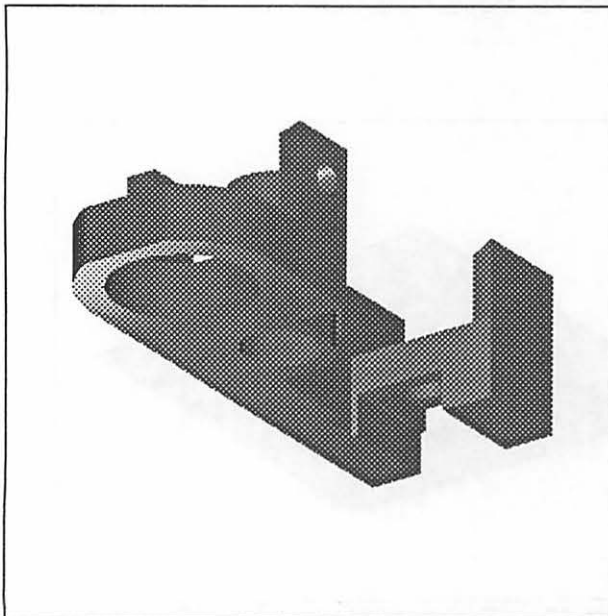

Figure 8. Different view of figure 7 model

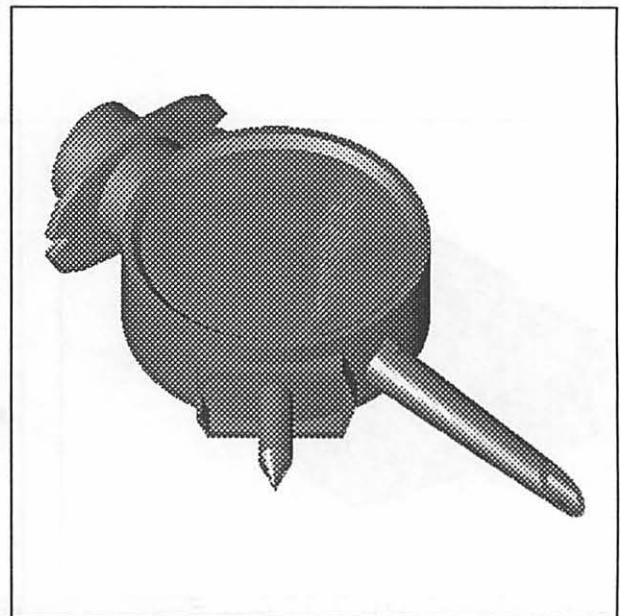

Figure 9. Still another Calma model

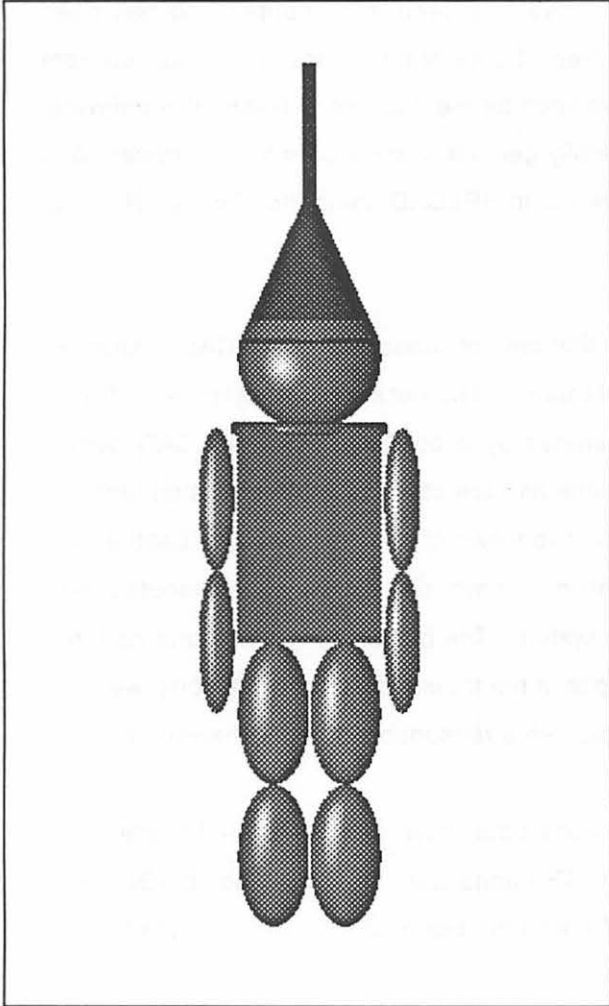

Figure 10. Original BRLCAD Model

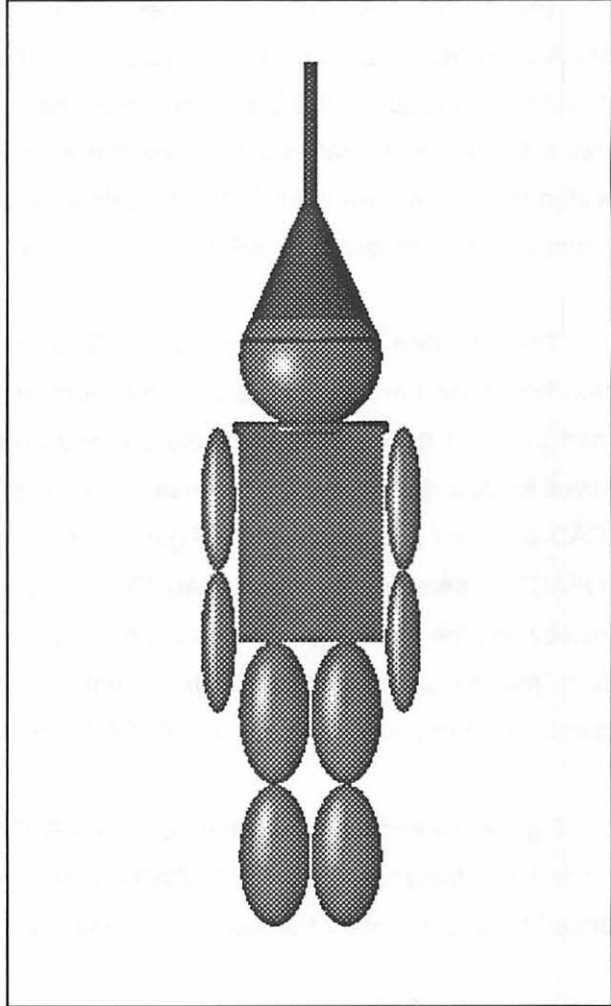

Figure 11. Model After Translation To/From IGES

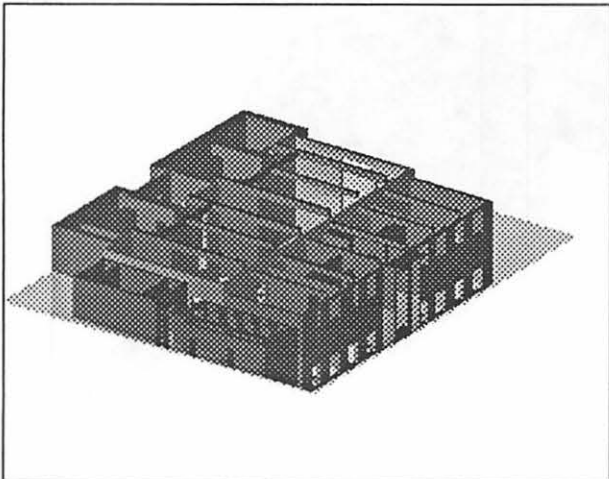

Figure 12. BRLCAD Model: Building Resting on a Mirror

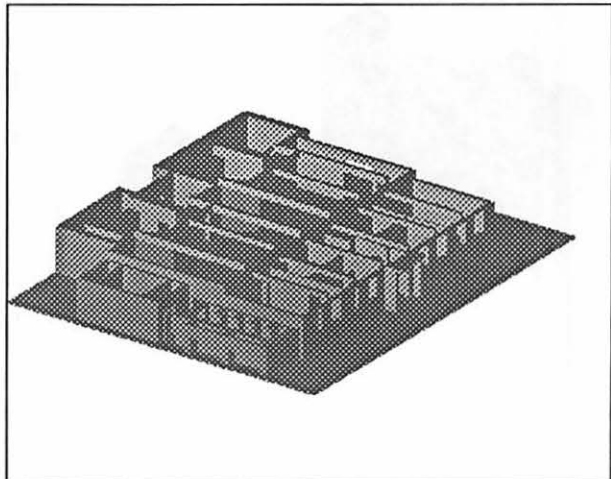

Figure 13. Figure 12 Model After Translation To/From IGES

woodsman model shown in figure 10 translated to and from IGES without loss of precision or geometry. Some nongeometry information was lost in the process, such as object names and material properties. In figure 12, a building rests on a mirrored surface, but that same building after translation to IGES and back rests on a geometrically equivalent surface that does not possess the mirror property. Object colors are translated by using a field in the object directory entry. This color field may contain either a color index referring to a predefined set of colors or a pointer to a color definition entity. The color definition entity allows colors to be specified by a three-tuple indicating red, green, and blue intensities similar to that used in BRLCAD, so the object color gets translated exactly. The current translator does not handle material properties or object names, although there are IGES entities available to support both these items.

IGES 4.0 also includes the capability to exchange a variety of three-dimensional surfaces. The BRLCAD translator takes advantage of this capability in a limited way by converting Non-Uniform Rational B-spline surfaces (NURBS) to a BRLCAD spline solid. Since there is no topology present for BREP models in IGES 4.0, there is no way to infer how to combine the NURBS to produce solids. This translator makes the assumption that all the NURBS in the IGES file are part of a single solid. This may not always be a correct assumption, but it at least provides a minimal translation capability for CAD systems that produce NURBS and NURB-surfaced solids. This feature is not intended to be a true BREP translator and will likely be replaced in future releases with a more rigorous approach.

This translator is distributed as part of the BRLCAD package and may be obtained by contacting the Survivability/Vulnerability Information Analysis Center (SURVIAC) at:

SURVIAC Aberdeen Satellite Office
1003 Old Philadelphia Road, Suite 103
Aberdeen, MD 21001 USA

or by electronic mail to <cad-dist@brl.mil>.

6. FUTURE PLANS

The current translator has limitations, as pointed out in the previous section, and is based on the current ANSI standard. We propose to continue work on the IGES-to-BRLCAD translator to eliminate the shortcomings discussed above and to extend its capabilities to include the latest IGES release (IGES 5.1). This would allow BRLCAD users to import solid models from virtually any CAD system that supports the IGES solid model transfer. The advantage of such a capability should be obvious: when solid models of military systems are available in a contractor's IGES-capable CAD system, it would virtually eliminate the duplication of effort now required to model that system in BRLCAD for vulnerability studies. Furthermore, such a capability would be in concert with the Department of Defense's Computer-aided Acquisition and Logistics Support (CALs) initiative.

We believe that the two IGES CSG solids that are approximated by the translator can be more accurately represented by either improving the approximation methods or by implementing and supporting a solid of revolution and a solid of linear extrusion into BRLCAD. The introduction of these solids as full-fledged BRLCAD primitives would eliminate any need for approximation. Short of adding new solids, improvements to these approximations are possible. For example, a circular arc in a solid of revolution can be accurately modeled by a portion of a torus, or an elliptical section of curve in a solid of linear extrusion can be modeled as a section of a BRLCAD *gentgc*. These types of improvements require considerable programming and cannot completely eliminate the need for a last resort approximation similar to the current method. However, because both of these solid types are based on two-dimensional curves and have simple generation schemes, they are both candidates for the application of the BRLCAD spline solid. To apply a spline approach, each section of the defining curve would be converted to a spline curve of appropriate order. Then the curves would be used to generate BRLCAD spline surfaces, which, when combined into a single BRLCAD spline solid, would create an extremely accurate model of the intended solid.

We hope to begin development of a BRLCAD-to-IGES translator. Development of a complete IGES translator package would position BRLCAD for easy introduction into any established CAD oriented work place. The capability to transfer designs back and forth between a designer's commercial CAD systems and BRLCAD would allow him access to BRLCAD's applications codes without disrupting his normal design process. This would also allow the designer to quickly and easily prepare a BRLCAD model of his design for submission in response to an Army Request for Proposals (RFP) or Source Selection Evaluation Board (SSEB), resulting in a cost saving for the Army. Such submissions have been required of Army materiel providers in the past and will likely continue to be required.

There are two inherent difficulties in developing a BRLCAD-to-IGES translator. First, BRLCAD has very flexible definitions for its primitive solids, allowing a wide range of possible shapes for the *gentgc* and the *genarb8* solids, for example. The IGES entities include special cases of these BRLCAD solids, but are not general enough to handle all cases. One approach to overcoming this problem is to persuade the IGES community to modify the IGES specification. The mechanism for accomplishing just that starts with a cooperative development and use of proposed, new IGES entities by two or more independent organizations. After a demonstrated implementation and exchange of data, the proposed entities may then be submitted to the IGES committee for review with the intent of inclusion in the specification (ultimately, inclusion in the ANSI standard). Another possible approach, which does not require modifying the specification, is to convert each unsupported (by IGES) BRLCAD CSG primitive into a BREP object. This approach also appears to be a viable solution, but actually leads us to the second difficulty.

BRLCAD is, for all practical purposes, a hybrid CAD system. Although BRLCAD primarily acts as a CSG system, it allows BREP objects to be intermingled among the CSG primitives. The IGES specification maintains a definite separation between CSG and BREP systems and does not allow the two to mix. The distinction is drawn in the definition of the IGES boolean tree, allowing only CSG primitives, solid instances, and other boolean trees as operands. No BREP entities may occur in an IGES boolean tree. Again, there are two possible solutions to the general incompatibility of BRLCAD trees containing BREPs and the IGES trees that cannot contain BREPS. Since IGES does not allow a mingling of CSG and BREP objects, one solution is to convert all the BRLCAD objects to BREP objects prior to translation. This may be possible in the near future as the BRLCAD *NMG* technology is perfected. In the near term, software can be written to tessellate all BRLCAD objects to form a type of BREP object with all flat, faceted faces. This approach will solve the problem, but the entire model would then be reduced to approximations. However, the reader should be aware that many CAD systems reduce their objects to faceted BREPs as the final form and usually permit the level of approximation (such as approximating a circle by a series of straight line segments) to be set by the user. Therefore, one can argue that although the resulting approximations might not be rigorously correct from a perfectionist's point of view, the faceted BREPs are usually acceptable for most applications—except for some signature applications. Eventually, the *NMG* objects are expected to be capable of supporting nonplanar surfaces such as spline surfaces; thus, more accurate versions of CSG objects could be constructed using the *NMG* solid. Even so, the conversion of the BRLCAD model to all *NMG* objects for the purpose of translation to IGES BREP will cause the loss of the original architecture of the model because only the BREP counterpart to the boolean tree—not the boolean tree itself—will be translated. Also, translation of the IGES BREP (formerly *NMG*) back to BRLCAD will not produce a model that is as easily edited and modified as the original boolean tree form of the CSG model. For example, a simple object that has a hole through it (in boolean tree form) is easily edited to change the size of the hole. However, the same object, after conversion to BREP and translation to/from IGES, presents some challenge to modify the surfaces that define the object's hole if the user requires the hole's size to be changed. But it should be noted that such a scenario would only occur if a BRLCAD model must be handed off to another CAD system and modified, then for some reason had to be translated back into BRLCAD. However one could make the assumption that once received from the other CAD system, the existing object(s) need no further modification; thus, the loss of the boolean tree in the process is not a significant shortcoming.

The second approach to this problem is, again, to influence the specification itself. Here, a small modification of just the IGES definition of the boolean tree would allow the faithful representation of any BRLCAD object in an IGES file. The complete and unaltered structure of a BRLCAD model could be preserved through translation to IGES and back to BRLCAD if the IGES boolean tree allowed BREP objects

as operands. This is clearly the optimal approach and one that the authors support.

7. RECOMMENDATIONS

BRLCAD should be made a useful tool for every CAD user—not just Army or Department of Defense users—by developing a complete IGES compatibility package. This package should extend beyond the solid modeling concerns presented in this report to include the generation of IGES files for any line drawing outputs BRLCAD may produce, such as *rthide* plots or *mged* plots. This complete package will enhance the usability and acceptability of BRLCAD throughout the CAD world.

The U.S. Army, and BRLCAD in particular, should be represented at meetings where IGES specifications and product data exchange standards are discussed and developed. Such representation has the potential to eliminate some of the difficulties of IGES translation for BRLCAD and may avoid future problems arising from decisions similar to those made in the past by the IGES committee (the separation of CSG and BREP, and the limited cases of certain CSG primitive solids). Private industry is heavily represented at these meetings, and without some demonstration of interest and influence by BRLCAD users/developers, all decisions made by the committee will be in the best interests of the attendees, regardless of the consequences they may hold for BRLCAD.

As IGES is developing to maturity, another candidate for product data exchange is still in its infancy. Product Data Exchange Using STEP (PDES) is a more comprehensive approach under development by an international organization (which includes the IGES committee as one part). The STEP portion of the PDES acronym represents the Standard for the Exchange of Product Model Data, which is the actual candidate for an international standard, while PDES is the U.S. effort supporting STEP. A satisfactory discussion of PDES is beyond the scope of this report, but the reader should be aware that PDES's potential use is considerably more than a mere replacement of IGES. PDES encompasses an order of magnitude greater scope and application than IGES. Whereas IGES is concerned with the *product definition* of an object (part, component, system), PDES's objective is to address the complete range of an object's *product data* (i.e., data relevant to the product's complete life cycle). As an analogy, comparing IGES to PDES is like comparing *nroff* to the UNIX operating system in terms of total scope and functionality.

Work on PDES dates back to the mid-1980s, but PDES has not demonstrated a capability that compares to IGES's capability when IGES was a little more than a half-decade old. That statement is not a criticism of PDES, but merely accentuates the enormous task that is the PDES effort. It is predicted that

possibly in ten years, PDES will be the method of choice for exchanging product definition data, including solid models. If PDES is eventually accepted as a standard by the International Standards Organization (ISO), then it is definitely in the best interests of the ARL to be actively participating in the development of this new specification. Many of the same people who developed IGES are heavily involved in PDES, and the ARL should be involved to insure that the development of specifications do not exclude capabilities demonstrated by BRLCAD.

...word
... ..
... ..
... ..
... ..

INTENTIONALLY LEFT BLANK.

REFERENCES

1. Kelly, J. C., R. Wolf, P. Kennicott, R. N. Nagel, and J. Wellington. "A Technical Briefing on the Initial Graphics Exchange Specification (IGES)." NBSIR 81-2297, National Bureau of Standards, Washington, DC, July 1981.
2. Nagel, R., W. W. Braithwaite, and P. R. Kennicott. "Initial Graphics Exchange Specification (IGES) Version 1.0." NBSIR 80-1978(R), National Bureau of Standards, Washington, DC, January 1980.
3. *Digital Representation for Communication of Product Definition Data*, Parts 1, 2, and 3, (Y14.26M-1981), American National Standards Institute, 1981. Permanently out of print.
4. Smith, B., G. R. Rinaudot, K. A. Reed, and T. Wright. "Initial Graphics Exchange Specification (IGES) Version 4.0." NBSIR 88-3813, National Bureau of Standards, Gaithersburg, MD, June 1988.
5. *Digital Representation for Communication of Product Definition Data* (ASME Y14.26M-1989), The American Society of Mechanical Engineers or the American National Standards Institute, New York City, NY, 1989.
6. Reed, K., J. C. Kelly, D. Harrod, Jr., and W. Conroy. "The Initial Graphics Exchange Specification (IGES) Version 5.1." National Computer Graphics Association, Administrator-IGES/PDES Organization, Fairfax, VA, September 1991.
7. IGES file provided courtesy of the Advanced Systems Research and Analysis Office of the Aviation and Troop Command at Moffett Field, CA, 1986.
8. These models were generated on a Calma system and used by the Structural Dynamics Research Corporation (SDRC) for testing of their IGES interface. The models were provided to ARL by SDRC.

1. The first paragraph of the contract states that the contractor shall be responsible for obtaining all necessary permits and licenses for the work to be performed. The contractor shall also be responsible for obtaining all necessary insurance coverage for the work.

2. The second paragraph of the contract states that the contractor shall be responsible for obtaining all necessary permits and licenses for the work to be performed. The contractor shall also be responsible for obtaining all necessary insurance coverage for the work.

3. The third paragraph of the contract states that the contractor shall be responsible for obtaining all necessary permits and licenses for the work to be performed. The contractor shall also be responsible for obtaining all necessary insurance coverage for the work.

4. The fourth paragraph of the contract states that the contractor shall be responsible for obtaining all necessary permits and licenses for the work to be performed. The contractor shall also be responsible for obtaining all necessary insurance coverage for the work.

5. The fifth paragraph of the contract states that the contractor shall be responsible for obtaining all necessary permits and licenses for the work to be performed. The contractor shall also be responsible for obtaining all necessary insurance coverage for the work.

INTENTIONALLY LEFT BLANK.

6. The sixth paragraph of the contract states that the contractor shall be responsible for obtaining all necessary permits and licenses for the work to be performed. The contractor shall also be responsible for obtaining all necessary insurance coverage for the work.

7. The seventh paragraph of the contract states that the contractor shall be responsible for obtaining all necessary permits and licenses for the work to be performed. The contractor shall also be responsible for obtaining all necessary insurance coverage for the work.

8. The eighth paragraph of the contract states that the contractor shall be responsible for obtaining all necessary permits and licenses for the work to be performed. The contractor shall also be responsible for obtaining all necessary insurance coverage for the work.

<u>No. of Copies</u>	<u>Organization</u>	<u>No. of Copies</u>	<u>Organization</u>
2	Administrator Defense Technical Info Center ATTN: DTIC-DDA Cameron Station Alexandria, VA 22304-6145	1	Commander U.S. Army Missile Command ATTN: AMSMI-RD-CS-R (DOC) Redstone Arsenal, AL 35898-5010
1	Commander U.S. Army Materiel Command ATTN: AMCAM 5001 Eisenhower Ave. Alexandria, VA 22333-0001	1	Commander U.S. Army Tank-Automotive Command ATTN: AMSTA-JSK (Armor Eng. Br.) Warren, MI 48397-5000
1	Director U.S. Army Research Laboratory ATTN: AMSRL-OP-CI-AD, Tech Publishing 2800 Powder Mill Rd. Adelphi, MD 20783-1145	1	Director U.S. Army TRADOC Analysis Command ATTN: ATRC-WSR White Sands Missile Range, NM 88002-5502
1	Director U.S. Army Research Laboratory ATTN: AMSRL-OP-CI-AD, Records Management 2800 Powder Mill Rd. Adelphi, MD 20783-1145	(Class. only) 1	Commandant U.S. Army Infantry School ATTN: ATSH-CD (Security Mgr.) Fort Benning, GA 31905-5660
2	Commander U.S. Army Armament Research, Development, and Engineering Center ATTN: SMCAR-IMI-I Picatinny Arsenal, NJ 07806-5000	(Unclass. only) 1	Commandant U.S. Army Infantry School ATTN: ATSH-WCB-O Fort Benning, GA 31905-5000
2	Commander U.S. Army Armament Research, Development, and Engineering Center ATTN: SMCAR-TDC Picatinny Arsenal, NJ 07806-5000	1	WL/MNOI Eglin AFB, FL 32542-5000 <u>Aberdeen Proving Ground</u>
1	Director Benet Weapons Laboratory U.S. Army Armament Research, Development, and Engineering Center ATTN: SMCAR-CCB-TL Watervliet, NY 12189-4050	2	Dir, USAMSAA ATTN: AMXSY-D AMXSY-MP, H. Cohen
1	Director U.S. Army Advanced Systems Research and Analysis Office (ATCOM) ATTN: AMSAT-R-NR, M/S 219-1 Ames Research Center Moffett Field, CA 94035-1000	1	Cdr, USATECOM ATTN: AMSTE-TC
		1	Dir, USAERDEC ATTN: SCBRD-RT
		1	Cdr, USACBDCOM ATTN: AMSCB-CII
		1	Dir, USARL ATTN: AMSRL-SL-I
		5	Dir, USARL ATTN: AMSRL-OP-CI-B (Tech Lib)

No. of
Copies Organization

Aberdeen Proving Ground

60 Dir, USARL
ATTN: AMSRL-SL-BV,
John R. Anderson (328)(30 cp)
AMSRL-SL-BA,
Earl P. Weaver (1065)(30 cp)

USER EVALUATION SHEET/CHANGE OF ADDRESS

This Laboratory undertakes a continuing effort to improve the quality of the reports it publishes. Your comments/answers to the items/questions below will aid us in our efforts.

1. ARL Report Number ARL-TR-315 Date of Report December 1993

2. Date Report Received _____

3. Does this report satisfy a need? (Comment on purpose, related project, or other area of interest for which the report will be used.) _____

4. Specifically, how is the report being used? (Information source, design data, procedure, source of ideas, etc.) _____

5. Has the information in this report led to any quantitative savings as far as man-hours or dollars saved, operating costs avoided, or efficiencies achieved, etc? If so, please elaborate. _____

6. General Comments. What do you think should be changed to improve future reports? (Indicate changes to organization, technical content, format, etc.) _____

CURRENT ADDRESS

Organization

Name

Street or P.O. Box No.

City, State, Zip Code

7. If indicating a Change of Address or Address Correction, please provide the Current or Correct address above and the Old or Incorrect address below.

OLD ADDRESS

Organization

Name

Street or P.O. Box No.

City, State, Zip Code

(Remove this sheet, fold as indicated, tape closed, and mail.)
(DO NOT STAPLE)

DEPARTMENT OF THE ARMY



OFFICIAL BUSINESS

BUSINESS REPLY MAIL
FIRST CLASS PERMIT No 0001, APG, MD

Postage will be paid by addressee.

NO POSTAGE
NECESSARY
IF MAILED
IN THE
UNITED STATES

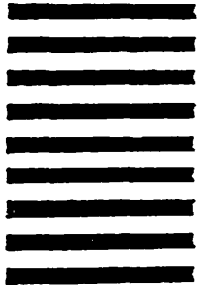

Director
U.S. Army Research Laboratory
ATTN: AMSRL-OP-CI-B (Tech Lib)
Aberdeen Proving Ground, MD 21005-5066
